

ENERVEX®

SMDS SEALED MODULATING DAMPER SYSTEM

009.2120.1118 03.22

Product Information

Use

The SMDS is a self-sensing, modulating damper and draft control system used to maintain a required pressure (negative or positive) for a common chimney or at individual appliance connector(s).

It can be used with Category I, II, III & IV heating appliance systems*.

Description

The system consists of an MDF Damper with high-pressure and high-temperature sealed bearings. The damper blade is positively sealed with an extremely durable, temperature, pressure and condensate resistant graphite gasket (Viton optional). It protects the boiler connectors from flue gas recirculation when used in a common vent system.

The unique damper design prevents condensate from pooling above the damper and the possibility of a slug of condensate flushing into the appliance at start-up.

The damper is controlled by an EBC24 Draft Controller that interlocks with the heating appliance(s) and controls the draft using a bi-directional or uni-directional XTP3 Pressure Transducer. The controller can be installed on the damper itself or remotely on a wall or in a boiler control, as it is prepared for DIN rail mounting.

Features

- The MDF damper is controlled via PID loop.
- Damper is UL-listed for condensing and non-condensing applications for temperatures up to 1400°F and pressures of up to 60 inWC.
- “Plug-n-Play” monitors all terminals and registers components attached.
- Pre-wired and pre-programmed makes installation easy.
- USB and Integrated webserver for remote monitoring, configuration and firmware upgrade
- Adjustable Bi-directional or uni-directional operating modes.
- Modbus protocol included

The control has LCD Graphical Display and integrated safety function and can be operated with either a manual or an automatic reset function. All terminal connections are monitored by LEDs for easy service and troubleshooting.

Material

Enclosure is made of polycarbonate and NEMA 4x rated. The entire damper is made of 316L-PCM Stainless Steel.



Standard Equipment

- Damper with high-pressure and high-temperature sealed bearings and actuator
- EBC 24 Control Unit
- XTP3 Sensor with condensate Stack Probe and Silicone Tubing

Listings

The EBC 24 Draft Controller:

- UL 378 Standard for Draft Equipment and UL 60947-4-1 Standard for Industrial Control Equipment
- CSA C22.2 No. 14-10 Standard for Industrial Control Equipment

The MDF Damper:

- UL 378 Standard for Draft Equipment and UL 17 Standard for Vent or Chimney Connector Dampers for Oil-Fired Appliances
- ULC/ORD-C378 (1975) Draft Equipment
- ANSI Z21.66-1996 Automatic Vent Damper Devices For Use With Gas-fired Appliances
- Meets all requirements of NFPA54 (ANSI Z223.1), National Fuel Gas Code, IFGC, International Fuel Gas Code and IMC, the International Mechanical Code and most other relevant codes.

Warranty

2-Year Factory Warranty. Complete warranty conditions are available from ENERVEX Inc.



UL File E484712
UL File E467733

ENERVEX Inc.
1685 Bluegrass Lakes Parkway
Alpharetta, GA 30004
USA

P: 770.587.3238
F: 770.587.4731
T: 800.255.2923
info@enervex.com
www.enervex.com

ENERVEX®
VENTING DESIGN SOLUTIONS

ENERVEX® SMDS SEALED MODULATING DAMPER SYSTEM

009.2120.1118 03.22

Product Information

Specifications

EBC 24 Control		
Power supply	V	1x120VAC / 60 Hz
Amperage	A	0.4T/6.3T/250V(JDYX2/8)
Operating temperature	°F/°C	-4 to 122 / -20 to 50
Range of operation	inWC / Pa	-1.00 to +1.00 / -250 to +250
Tolerance	inWC / Pa	0.01 / 3 +/-10%
Output Current	mA	max. 10
Max. Load		120 VAC / 8A
Real-time PID Control Method		Infinitely variable
Real-time PID Signal Stability		+/- 0.5%
Ramp Up/Down Time	Seconds	max 20
Output	VDC	0-10
EMC standard	Emission	UL 60947
	Immunity	EN50 082-2
XTP3 Sensor		
Mode		Bi-directional
Power supply	VDC	12-36 / 24V
Amperage	mA	<20
Output	VDC	0-10
Operating temperature	°F / °C	0 to 160 / -18 to 71
Accuracy		+/- 0.08%

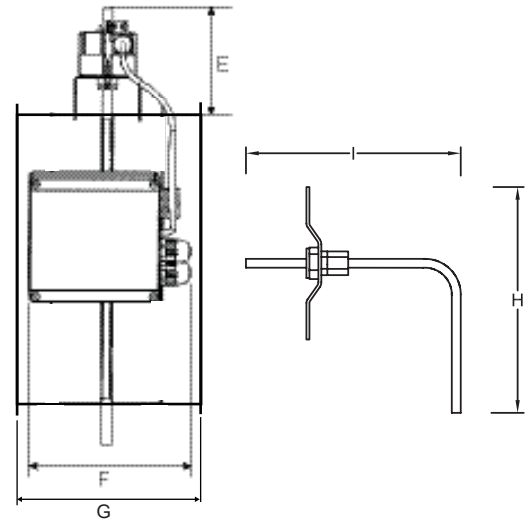
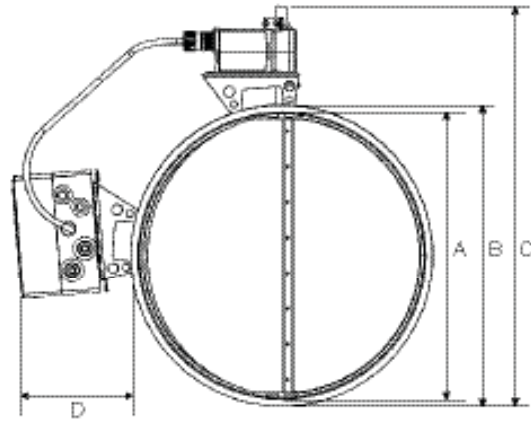

Dimensions

in/mm	SDF 4	SDF 6	SDF 8	SDF 10	SDF 12	SDF 14	SDF 16	SDF 18
A	3.94 / 100	5.91 / 150	7.87 / 200	9.84 / 250	11.81 / 300	13.78 / 350	15.75 / 400	18.00 / 457
B	4.88 / 124	6.85 / 174	8.82 / 224	10.79 / 274	12.76 / 324	14.72 / 374	16.69 / 424	19.00 (483)
C	8.86 / 225	10.83 / 275	12.80 / 325	14.76 / 375	16.73 / 425	18.70 / 475	20.67 / 525	22.91 / 582
D	5.13 / 130	5.13 / 130	5.13 / 130	5.13 / 130	5.13 / 130	5.13 / 130	5.13 / 130	5.13 / 130
E	5.04 / 128	5.04 / 128	5.04 / 128	5.04 / 128	5.04 / 128	5.04 / 128	5.04 / 128	5.04 / 128
F	6.89 / 175	6.89 / 175	6.89 / 175	6.89 / 175	6.89 / 175	6.89 / 175	6.89 / 175	6.89 / 175
G	8.00 / 203	8.00 / 203	8.00 / 203	8.00 / 203	8.00 / 203	8.00 / 203	8.00 / 203	8.00 / 203
H	4.25 / 108	4.25 / 108	4.25 / 108	4.25 / 108	4.25 / 108	4.25 / 108	4.25 / 108	4.25 / 108
I	3.50 / 89	3.50 / 89	3.50 / 89	3.50 / 89	3.50 / 89	3.50 / 89	3.50 / 89	3.50 / 89

Specifications are subject to change without notice.

ENERVEX Inc.
1685 Bluegrass Lakes Parkway
Alpharetta, GA 30004
USA

P: 770.587.3238
F: 770.587.4731
T: 800.255.2923
info@enervex.com
www.enervex.com

ENERVEX®
VENTING DESIGN SOLUTIONS